

Super-structure Generation for Separation Network Synthesis Involving Different Separation Methods

I. Heckl¹, Z. Kovács^{1,2}, F. Friedler^{1,3}, and L. T. Fan³

¹Department of Computer Science, University of Veszprém, Veszprém, Hungary

²Department of Computer Science, University of Szeged, Szeged, Hungary

³Department of Chemical Engineering, Kansas State University, Manhattan, KS 66506, U.S.A

The separation network synthesis (SNS) is a major research field of process synthesis. A separation network comprises separators, mixers, and dividers, collectively called operating units, through which multi-component streams flow while being processed. Various combinations of the operating units, usually give rise to a multitude of complex networks. The aim of SNS is to combine operating units so that the resultant network generates the desired products with the lowest possible cost. A procedure for generating rigorous super-structures is proposed herein. The objective of the current work is to solve SNS problems in which the candidate separators are affected by different mechanisms. Such mechanisms are always based on different physical or chemical properties of the components to be separated, e.g., volatility, solubility, permeability, adsorbability, and density. The majority of SNS methods, however, takes into account only a single property, mainly the volatility. The current work introduces a novel algorithmic method for generating the super-structure and the related mathematical-programming model for a class of SNS problems, which involves any number of components, feeds and products and the available separators can be based on different mechanisms. For simplicity, the separators are regarded to be of the simple and sharp type, and the cost of a separator is linear. The efficacy of the algorithm is illustrated by an on-line demonstration.

1. Introduction

The significance of SNS is obvious: separation processes and networks are ubiquitous throughout the chemical and allied industries where a sequence of separation tasks must be performed to produce the desired products. The energy demands of separation tasks are usually inordinately high; moreover, separators are often capital intensive. Thus, optimizing separation networks tends to substantially reduce the cost of production.

A separation network comprises separators, mixers, and dividers through which multi-component streams flow while being processed. Various combinations of the separators, mixers, and dividers give rise to a multitude of networks, which differ from one another according to their intended purposes. The aim of a SNS problem is to configure the optimal separation network for generating the desired products from the given feeds under the constraints imposed. A typical example is the crude oil separation in which a countless number of products are manufactured. Numerous methods are available in the literature for solving various SNS problems. These methods are mainly classified according to the search techniques for solution; they can be heuristic (Fonyó et al., 1985) or algorithmic (Floudas, 1987; Quesada and Grossmann, 1995; Kovács et al., 2000).

The objective of the current work is to establish a procedure for generating rigorous super-structures, which are required to solve SNS problems involving various types of candidate separators that perform separations effected by different mechanisms. Such mechanisms are naturally based on different physical or chemical properties of components in the mixture to be separated, e.g., volatility, solubility, permeability, absorptability and density. Specifically, the current contribution introduces a novel algorithmic method for generating the super-structure and the concomitant mathematical-programming model for a class of SNS problems, which can be stated as follows: Determine the cost-optimal separation network for transforming the compositions of n -component feed streams to obtain 2 or more n -component product streams with a given set of simple and sharp separators based on separation methods effected by different mechanisms. The separators' costs are regarded as linear functions of the respective feed rates without additive constant parameters.

2. Features of Separation Networks

A separation network can be characterized by several key features. Some are the attributes of mixtures, i.e., streams, and their components to be separated, and others pertain to the devices performing the separation in the network.

The first feature of a separation network is the component order. A separation is always carried out by exploiting the difference in the magnitude of one of the properties of the components in the streams of mixtures, which are to be separated. The components in the streams and their amounts are usually ordered according to the property on which the separation is based. Situations often arise in which the separation of a stream can be carried out with various separators, based on separation methods effected by different mechanisms. This necessitates the decision as to which mechanism will be the base of the component order. Separation induced by the difference in volatility has long been ubiquitous in practice. Nevertheless, the implementation of methods of separation induced by the differences in other properties has been steadily gaining popularity in recent years: these methods are potentially capable of leading to substantially energy saving and profound simplification in designing separation networks. The second feature of a separation network is the properties of a separator. A simple and sharp separator partitions the components in the input stream into two output streams so that each component appears only in one of the output streams. Naturally, n components in the feed stream may give rise to $(n-1)$ separations using one separation method.

Suppose that k varieties of properties can be identified in an n -component system, which can be exploited to affect the separation. This leads to a maximum of $k(n-1)$ separations. Each separator can be described by the sets of components which can appear at the inlet, top and bottom product of the separator. If the separation between components not adjacent to each other is possible, additional separators can be incorporated into the system. Apparently, little has been done in this regard. In the current work, the cost of a separator is given as a linear function of its mass load without an additive constant parameter. There are other operating units besides the separators in a separation network namely the mixers and dividers. Their properties are important characteristics of the network as well. These devices are for routing streams; their costs are regarded negligible herein. A mixer blends two or more input streams, thereby increasing the amounts of the components in the resultant stream. A divider

physically or mechanically splits one input stream. Thus, the component ratios in all the resultant output streams remain identical to those of the input stream.

3. Generation of the Super-structure

The algorithmic solution of any SNS problem involves the following major steps; the construction of the network's structural model, the generation of the linear or nonlinear mathematical-programming model, and the solution of this model. Thus, if the mathematical model is based on an inadequate structural model, it would be uncertain that the optimal solution of the original problem could be obtained.

The structural characteristics of the class of the SNS problems must be analyzed at the outset to ascertain that the super-structure for this class of problems. The following defines the important structural property of the optimal networks pertinent to the generation of the rigorous super-structure of the current SNS problem (Kovács et al., 2000).

Property 1: Each instance of a class of SNS problems of interest gives rise to an acyclic optimal network in which mixers are attached only to the output streams.

The proof for this statement does not demand that the separators be based only on a single separation method. Its significance is that it fixes the positions of the mixers in the rigorous super-structure, thereby greatly reducing the number of configurations to be explored. The super-structure can be generated by adapting the method proposed by Kovács et al. (2000). In step 1, one divider is created for each feed-stream and each divider is linked to the corresponding feed-stream, and in step 2, one mixer is created for each product-stream and each mixer is linked to the corresponding product-stream. Step 3 creates a separator for each possible cut and a bypass to each mixer created in step 2, both of which are connected to a divider created in step 1. Step 4 generates a divider for each of the outputs from the separators created in step 3. Hereafter, steps 3 and 4 are iterated, repeatedly until the complete super-structure is generated. It is worth noting that creating of a bypass between an output of any divider and a mixer is possible only when every component in the former appears in the product-stream from the latter.

Whenever a group of plausible separators is linked to a divider, it is plausible that the group comprises various separators based on different separation methods yielding the same outputs from a given input. Then, only the least-cost separator within the group is connected to the divider. This situation is impossible when all the separators involved are based on a single separation method.

The method for generating the super-structure proposed herein takes into account every structure for which property 1 holds. Consequently, it ensures that the solution of the resultant mathematical model belonging to the super-structure gives rise to the global optimum. Notice that the size of the super-structure is magnified progressively with the increase in the number of components and with the increase in the number of separator types; nevertheless, the simplicity of the resulting mathematical model is hardly unaffected.

4. Mathematical Model

The proposed mathematical-programming model remains linear as long as the cost function is defined to be linear, which is of immense practical significance: Any of the previously known models remains nonlinear even if the cost function is defined to be linear. On one hand formulating the mathematical model in terms of the compositions and total flow rates introduces non-convex terms in mass-balance equations (Quesada and Grossmann, 1995). On the other hand, formulating the mathematical model in terms of the component flow rates and splitting ratios renders the governing equations of the dividers non-convex (Floudas, 1987). In the current model, variable x_{ij} represents the fraction of the rate of the feed stream in output j from divider i ; therefore, this variable can be conveniently termed, "feed-allocation ratio," in analogy to the conventionally defined splitting ratio.

The objective, or overall cost, function is the weighted sum of the flow rates of the separators, where the weights are the overall cost coefficients comprising both the degree of difficulty of separation and the cost coefficient of the separators. There are non-negativity constraints for the feed-allocation ratios, material balances for the dividers, material balances for mixers, which make them possible to meet the product specifications. The structural properties of the super-structure are incorporated in the model. It is worth noting that the resultant mathematical model is totally linear; this can be attributed to the fact that the model is defined in terms of the feed-allocation ratios. Any linear programming model can be readily solved even if it contains an exceedingly large number of variables. If the cost of a separation is not linear with an additive constant, then property 1 no longer holds, and thus, the proposed method is inapplicable.

After the solution of the mathematical model we examine if two or more separation devices of the same kind in the optimal structure can be merged. Merging of such separators does not affect the structure's cost because of the linearity of the cost function as defined by the model.

5. Example

Given two seven-component streams from which four multi-component product streams are to be produced. Noted in Figure 1 are the amounts of the components in the feed and product streams. The separation can be carried out by resorting to two separation methods, extraction and distillation. Table 1 lists the component order for each separation method and the cost of separation between the components by each method.

The super-structure, the mathematical model, and the optimal structure (Figure 1) of the example have been generated in 24s on a PC (AMD-XP 2000+) according to the proposed algorithm. The super-structure contains 6,348 separators and 12,698 dividers. The mathematical model generated from the super-structure contains 12,726 constraints and 57,140 variables. The corresponding cost of the optimal separation network is 261.074; in contrast, the cost of the optimal network comprising only the separators based on distillation is 442.13, and that comprising only the separators based on extraction is 358.529.

Table 1. Component orders and separator costs for the example

Distillation							
Component Order	A	B	C	D	E	F	G
Separators	Sa12	Sa23	Sa34	Sa45	Sa56	Sa67	
Costs	1.5	3	2	2.5	4	4	
Extraction							
Component Order	D	F	C	A	G	B	E
Separators	Sb12	Sb23	Sb34	Sb45	Sb56	Sb67	
Costs	4.5	1	2.5	3.5	1.75	4.5	

6. Concluding Remarks

A systematic procedure is proposed constructing the super-structure for a novel class of separation-network synthesis problems involving various types of separators based on different separation methods. The efficacy of the proposed method is amply demonstrated with an example.

References

- Floudas, C. A., 1987, Separation synthesis of multicomponent feed streams into Multicomponent product streams, *American Institute of Chemical Engineering Journal*, 33, 540-550.
- Fonyó, Z., I. Mészáros, E. Rév and M. Kaszás, 1985, Pinch Oriented Synthesis Strategy for Multicomponent Separation Systems with Energy Integration, *Hung. J. Ind. Chem.*, 13, 121-134.
- King, J. C., 1980, *Separation Processes*, McGraw-Hill, pp. 729-730.
- Kovács, Z., Z. Ercsey, F. Friedler and L. T. Fan, 2000, Separation-Network Synthesis: Global Optimum through Rigorous Super-Structure, *Computers Chem. Engng.*, 24, 1881-1900.
- Quesada, I. and I. E. Grossmann, 1995, Global Optimization of Bilinear Process Networks with Multicomponent Flows, *Computers Chem. Engng.*, 19, 1219-12.

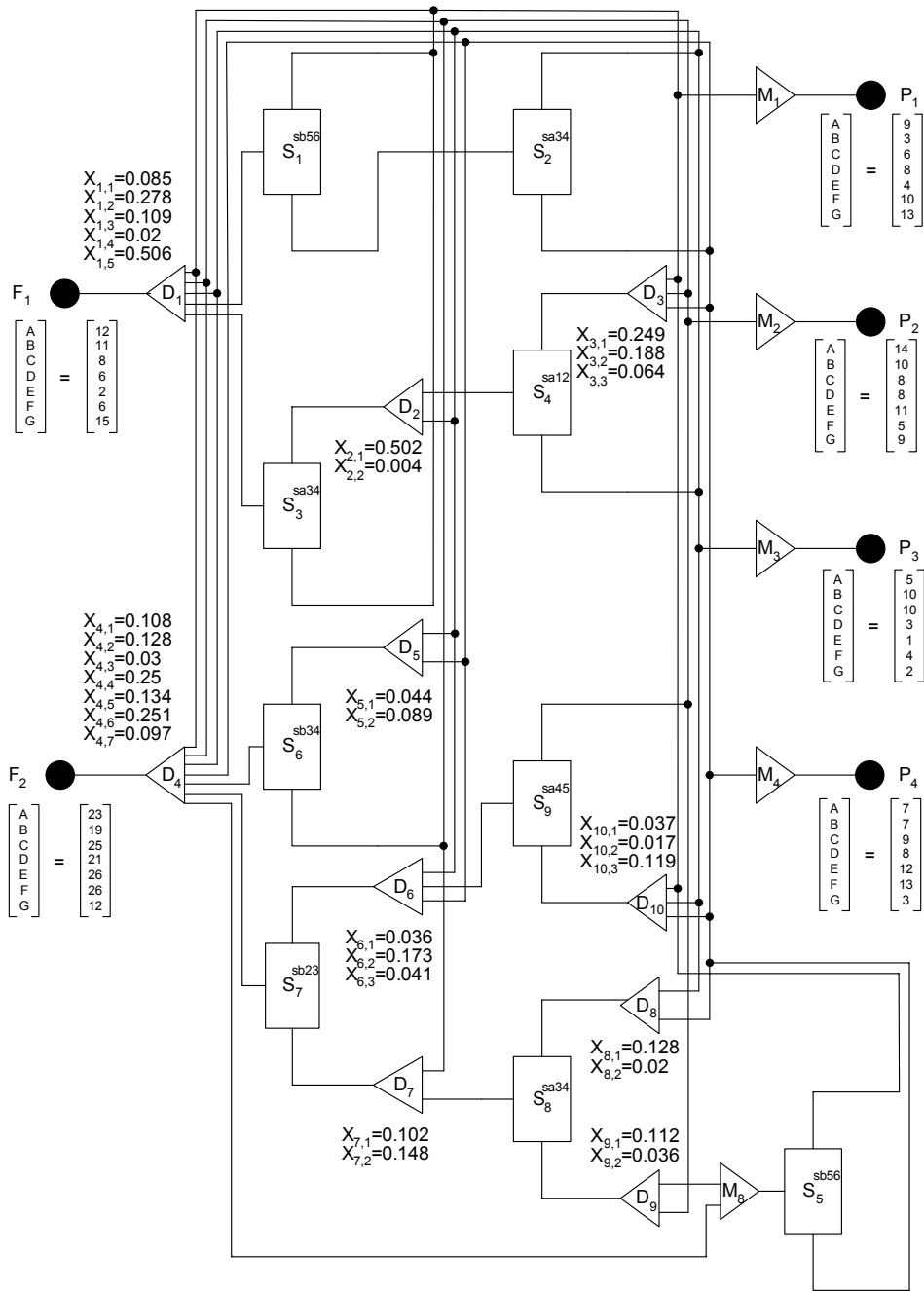

Figure 1. Optimal structure of the example